

(Project No.)  
(Date)

(Project Name)  
(Project Location)

**ARCHITECT & ENGINEER SPECIFICATIONS  
SECTION:  
REMOTE CAMERA DEVICES AND SENSORS**

**SRG-A40 / A12**

**IP 4K Pan Tilt Zoom camera with NDI | HX capability**

**(Software version 2.0 or later)**

**PRODUCTS**

**REMOTE CAMERA SPECIFICATIONS**

Table of Contents

A. MAIN FEATURES.....	2
B. CAMERA .....	5
C. CAMERA FEATURES .....	7
D. VIDEO .....	8
E. SYSTEM REQUIREMENTS & NETWORK .....	11
F. INTERFACES.....	12
G. GENERAL SPECIFICATIONS.....	15
H. REGULATORY SPECIFICATIONS .....	16
I. SUPPLIED ACCESSORIES .....	17
J. OPTIONAL ACCESSORIES.....	17
K. DIMENSIONS.....	18

## A. MAIN FEATURES:

1. IP 4K Pan Tilt Zoom camera with PTZ Auto Framing and NDI | HX capability (via optional license).
2. The sensitive 1/2.5-type Exmor R sensor shall capture high-quality 4K images with very low noise, even in dimly-lit environments.
3. High quality 20x optical zoom and 30x (4K) or 40x (FHD) with Clear Image Zoom:  
The high quality lens with 20x optical zoom range shall cover wide angle shots as well as tight close-ups. Clear Image Zoom shall expand this range to 30x (4K) or 40x (FHD) without sacrificing detail. In addition, the Tele Convert Mode shall be able to double this range again, up to 80x zoom while maintaining a 1920 x 1080 resolution.
4. The camera shall cover the whole scene in sports arenas and lecture theatres with a horizontal viewing angle of approx. 70°.
5. PTZ Auto Framing function shall automatically rotates the camera up, down, left, right, and zooms in or out. It keeps shooting a moving subject under an optimum composition. The camera automatically shoots natural and smooth video as if there were skilled operators operating the camera.

-Skeleton detection and head detection determine the optimal angle of view while detecting the subject regardless of the subject's posture (backwards, sitting, etc.) or hiding (mask, sunglasses, etc.)

- Grasp the color/texture of clothes with detailed feature extraction, and keep tracking the target subject even when people overlap or cross each other

- With face recognition, the face of the selected subject can be automatically registered and automatically recovered when tracking is lost.

- Keep everyone in the picture with Multi-person Framing\*. It can automatically track a group of up to eight people, with a primary subject and secondary subjects. The primary subject can be specified via the camera's Face Registration function\*, or on the web app screen. The secondary subjects are automatically selected according to their proximity to the primary subject. The camera's pan, tilt and zoom function ensures that the selected people are included in the image, with natural looking framing.

\*Multi-person Framing and Face Registration functions are available from firmware version 2.0 or later.

- Prioritize presenters with Face Registration\*. It can register the primary subject, tracking them reliably based on pre-registered face data and tracking priority. Automatic start/return is also enhanced, using registered face information to quickly re-acquire the subject after lost tracking or mis-tracking. \* Face Registration is available from firmware version 2.0 or later.

- Shoot with the intended angle of view. Camera functions can also be controlled remotely using web app software on a networked PC. This allows easy and optimal adjustment of the composition (size and position) of the subject with intuitive drag operations\*. It offers a wide range of picture composition options, with 24 subject sizes from full body to close-up, and detailed left/right and up/down settings. Scene composition can also be changed at any time, even when PTZ Auto Framing is active. \* Available from firmware version 2.0 or later.

- It is possible to automatically start tracking a subject that enters a pre-specified area.

- It is possible to automatically stop tracking when the subject being tracked turns around for a certain period of time.

- When auto framing is running, you can see that it is working by issuing a green tally lamp.

- Realizes stable camera work without following subtle movements such as light bows

6. NDI | HX compatibility (via optional license) shall support efficient IP-based live production, allowing flexible configuration with other networked NDI-enabled devices.
7. The camera shall capture the presenter's movements with maximum 300°/s pan and tilt movement during preset recall.
8. PTZ Motion Sync function shall allow smooth blending of separate pan, tilt and zoom movements for seamless, professional-looking transitions.
9. Excellent low light sensitivity:  
The camera shall be able to capture crisp, low noise color video images in light levels as low as 1.6 lx, making it an ideal choice for dimly-lit live hall and theater.

10. Flexible installation:  
Integration shall be simplified in a wide range of environments, with PoE++ (Power over Ethernet Plus Plus) to reduce cabling requirements and IP based remote control(VISCA control over IP and CGI command).
11. Remote operation:  
Pan/tilt/zoom and other camera settings shall be able to be controlled using the supplied IR remote commander, or with the optional RM-IP500 / IP10 Remote Control Unit that can control multiple cameras.
12. Versatile video outputs:  
Greater installation flexibility in professional broadcast and AV environments with 3G-SDI and HDMI video outputs. In addition to SDI/HDMI output, IP network transmission shall be able to be performed simultaneously by streaming function (SDI output does not support 4K). For streaming function, ITU-T H.264/H.265 shall apply to video compression mode (video codec) and it shall achieve high compression rate while maintaining the image quality. Also, it shall decrease the network bandwidth load. Moreover, the camera shall support multi-streaming output. Up to 3 codec modes shall be able to be selected.
13. Front tally lamps:  
Ideal for on-air broadcast use, this camera features a red tally lamp on the front of the camera body. It also has a green tally lamp that displays the tracking status during PTZ Auto Framing operation. The front tally lamp can be set to 2 levels of brightness.

## B. CAMERA:

1. The camera shall utilize a 1/2.5-type back-illuminated "Exmor R" CMOS sensor.
2. The number of effective pixels shall be approx. 8.5 Megapixels.
3. The camera shall require a minimum scene illumination of: 1.6 lx (1/30s 50IRE F2 high-sensitivity OFF)
4. The camera shall have a gain-controlled capability of Auto/Manual. It shall be selected from 0 dB to +48 dB manually.
5. The electronic shutter speed shall be set from 1/1 to 1/10000s (59.94 Hz / 29.98 Hz / 50 Hz).
6. White balance shall be selected among Auto1, Auto2, One Push WB, Indoor, Outdoor or Manual settings.
7. The camera shall have 20x optical zoom and 30x (4K) or 40x (FHD) with Clear Image Zoom capabilities.
8. The viewing angle shall be: Horizontal: approx. 70 ° (wide)
9. The focal length shall be
  - f = 4.4mm to 88.0mm, F2.0 (Wide) to F3.8 (Tele).  
f = 26.8 mm to 536.0 mm (35 mm camera conversion)  
(SRG-A40).
  - f = 4.4 mm to 52.8 mm, F2.0 to F3.7  
f = 26.8 mm to 322.8 mm (35 mm camera conversion)  
(SRG-A12).
10. The minimum object distance shall be
  - 80mm (Wide) to 800mm (Tele).  
(SRG-A40)
  - 80mm (Wide) to 400mm (Tele).  
(SRG-A12)
11. The pan/tilt angle shall be Pan:  $\pm 170^\circ$  Tilt:  $+90^\circ/-20^\circ$
12. The maximum pan/tilt speed shall be
  - Pan:  $1.1^\circ$  to  $101^\circ/\text{sec}$
  - Tilt:  $1.1^\circ$  to  $91^\circ/\text{sec}$

13. The number of preset positions shall be 256 positions (CGI) and 100 positions (VISCA).

### C. CAMERA FEATURES:

1. The camera shall have an image flip function to support the ceiling mount.
2. The camera shall have a Day/Night (D/N) function to switch to Day mode (color mode) or Night mode (black and white mode).  
The Day/Night ICR Auto mode shall be able to switch automatically between Day/Night by removing IR cut filter. (The threshold can be chosen from 0 to 255 to switch from Night mode to Day mode.)
3. The camera shall have Visibility Enhancer function to optimize the brightness and color reproduction of an image dynamically.

## D. VIDEO:

1. The signal system shall be as follows.

3840 × 2160/29.97p \*1  
1920 × 1080/59.94p  
1920 × 1080/59.94i  
1920 × 1080/29.97p  
1280 × 720/59.94p  
3840 × 2160/25p \*1  
1920 × 1080/50p  
1920 × 1080/50i  
1920 × 1080/25p  
1280 × 720/50p  
3840 × 2160/23.98p \*1  
1920 × 1080/23.98p

2. The image size (resolution and frame rate) of the signals delivered through the SDI OUTPUT, the HDMI OUTPUT terminal and IP Streaming shall be able to be change with the SYSTEM SELECT switch.  
Switching of Level-A / Level-B of 3G-SDI shall be set by No.1 SDI format / level settings of CAMERA SETUP switches.

SYSTEM SELECT switch settings are shown below:



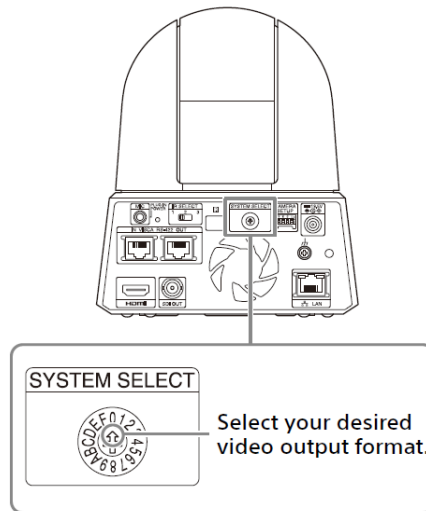

No.	Video output format/Frame rate
0	3840x2160/29.97p
1	1920x1080/59.94p
2	1920x1080/59.94i
3	1920x1080/29.97p
4	1280x720/59.94p
5	RESERVE
6	REMOTE
7	HDMI : 640x480/59.94p SDI OUT : 1280x720/59.94p
8	3840x2160/25p
9	1920x1080/50p
A	1920x1080/50i
B	1920x1080/25p
C	1280x720/50p
D	RESERVE
E	3840x2160/23.98p
F	1920x1080/23.98p

### CAMERA SETUP switch settings

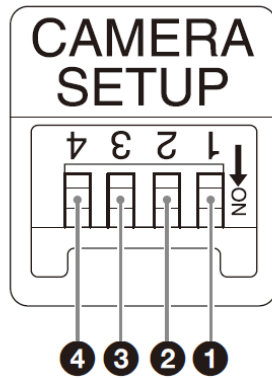

Switch No.	Setting items
1	SDI format/level settings
2	RESERVED
3	VISCA connect setting
4	Baud Rate settings of RS-422 for VISCA communication

## E. SYSTEM REQUIREMENTS & NETWORK:

1. The supported OS (operating systems) and web browser shall be
  - Windows
    - OS version
      - Windows 11 (64-bit version)
      - Windows 10 (64-bit version)
    - Web browser
      - Google Chrome (Recommended)
      - Microsoft Edge
  - Mac OS
    - OS version
      - macOS 11
      - macOS 12
    - Web browser
      - Google Chrome

## F. INTERFACES:

1. The camera shall have the following output terminals.

### HDMI OUT

Terminal: HDMI connector (Type A) × 1

Standards: Version 1.4b compatible

Color space: YCbCr, 4:2:2 8bit RGB, 4:4:4 8bit

### SDI OUT

Terminal: BNC connector × 1

Standards: 3G-SDI

2. The camera shall have the following input and output terminals.

### VISCA RS-422

Terminal: RJ45 × 2

Standards: VISCA

### LAN

Terminal: RJ45

Standards: IEEE802.3bt type4 Class8 compatible (PoE++)

Pin array and the connection diagram with remote control unit RM-IP10 are shown below:

---

## Pin array of the VISCA RS-422 terminal and how to use it

### Pin array of VISCA RS-422 terminal

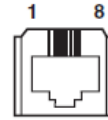
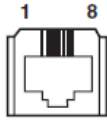

#### IN

Pin No.	Function
1	TX-
2	TX+
3	RX-
4	GND
5	GND
6	RX+
7	N.C.
8	N.C.

#### OUT

Pin No.	Function
1	RX-
2	RX+
3	TX-
4	GND
5	GND
6	TX+
7	N.C.
8	N.C.

## Connection diagram with remote control unit RM-IP10

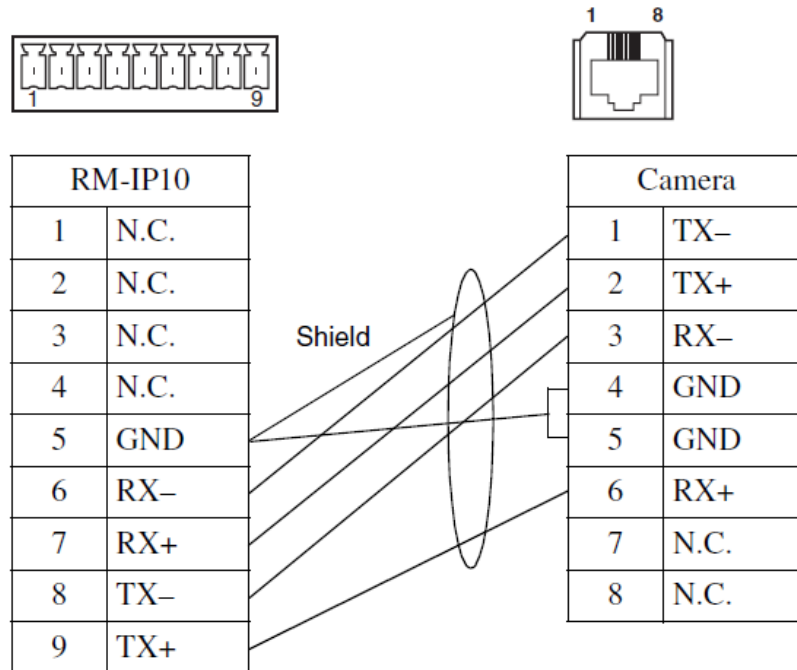

### Notes

- Connect the GNDs of both devices together to stabilize the voltage level of the signal.
- When preparing cables, use network cables of category 5e or more. Use cables equivalent to or higher than shielded twisted pair cables.

3. The camera shall have the following input terminals..

MIC

Terminal: Mini jack  $\varnothing$  3.5 ( $\times 2$ ) (Plug in Power supported)

Power terminal

IEC60130-10 (JEITA standard RC-5320A) TYPE 5

## G. GENERAL SPECIFICATIONS:

1. The camera input power shall be IEEE802.3bt type4 Class8 compatible (PoE++) and DC 19.5 V.
2. Power consumption for the camera shall be 80W for DC 12 V and 71.3 W for PoE++.
3. The camera operating temperature shall be within the following range:  
+32 °F to +104 °F (0 °C to +40 °C)
4. The camera storage temperature shall be within the following range:  
-4 °F to +140 °F (-20 °C to +60 °C)
5. The camera dimensions (W x H x D) shall be approximately:  
6 1/4 × 7 1/4 × 7 7/8 inches (156.7 × 184.0 × 200.0 mm) (without protrusions)
6. The camera shall weigh approximately 4 lb 6.5 oz (2.0 kg).
7. The body color shall be black or white.

H. REGULATORY SPECIFICATIONS:

1. CB (IEC62368-1:14)
2. EMC (EN55032:2015(Class A), EN55035:2017)
3. FCC/ISED (Class A Digital Device)
4. UL (UL62368-1, CSA C22.2 No.62368-1)
5. VCCI (Class A)
6. BIS 616 (IEC60065)
7. NOM-001
8. KC (MSIT) (KN32(A), KN35)
9. KC (SDoC) (K62368-1))



10. I. SUPPLIED ACCESSORIES:

1. Safety Regulations (1)
2. AC adapter (1)
3. IR Remote commander (1)
4. Ceiling bracket (A) (1)
5. Ceiling bracket (B) (1)
6. Wire rope (1)
7. Mounting screws (↕ M3 × 8) (9)
8. Mounting screws (↕ M2.6 × 6 black) (1)
9. HDMI cable fixing plate (1)

J. OPTIONAL ACCESSORIES:

1. Remote controller (RM-IP500/IP10)

K. DIMENSIONS:

Top

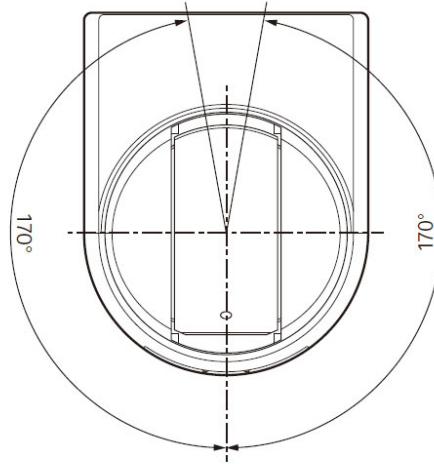

Front

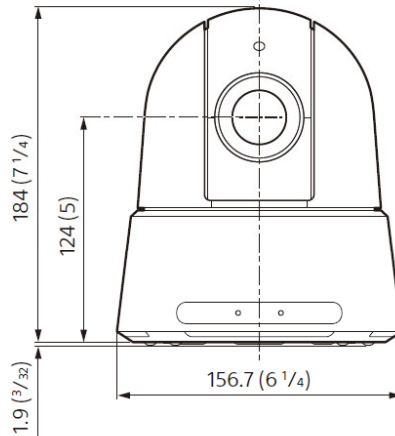

Side

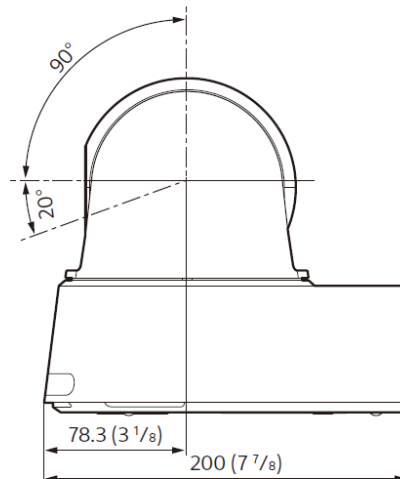

Unit: mm (inches)

**Bottom**

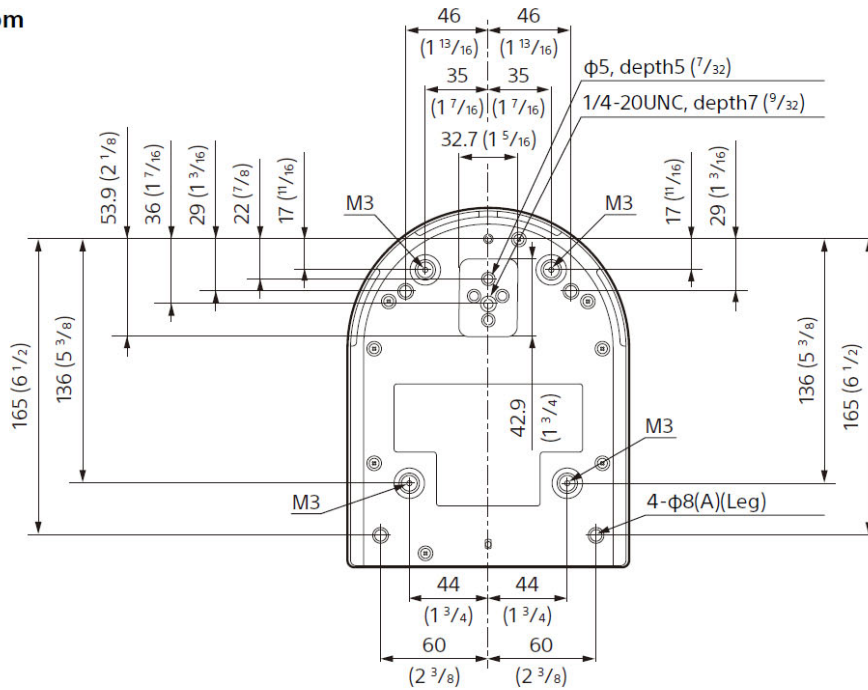

**Ceiling bracket (B)**

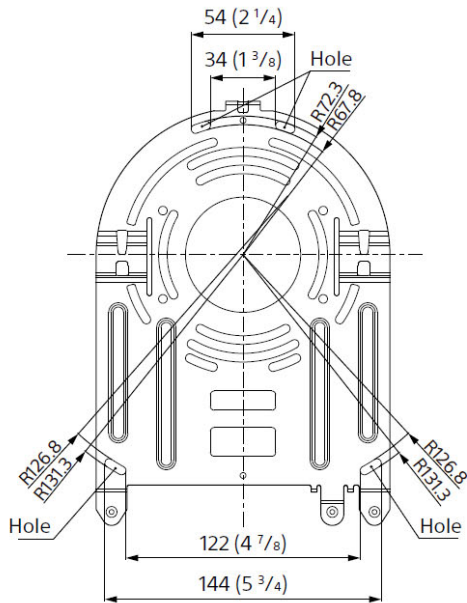

**With the ceiling bracket installed**

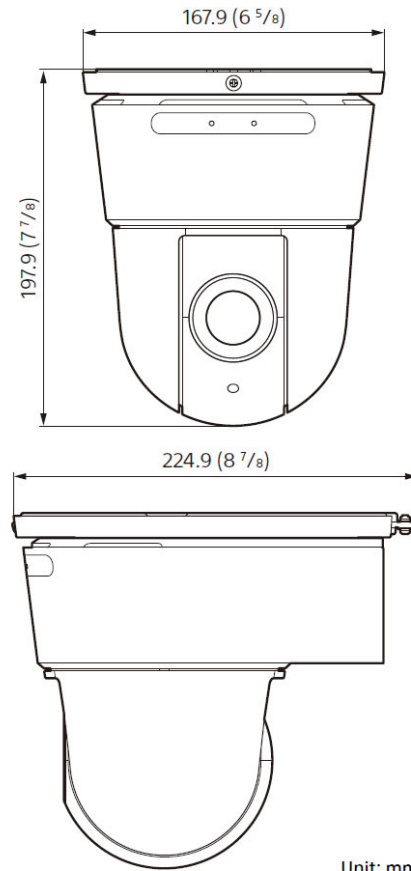

Unit: mm (inches)

©2023 Sony Corp.

Features and specifications are subject to change without notice. Non-metric weights and measurements are approximate.

Sony is a registered trademark of Sony Corporation.  
"Exmor R" is a trademark of Sony Corporation.

Microsoft, Windows and Edge are either registered trademarks or trademarks of Microsoft Corporation in the United States and/or other countries.

HDMI, HDMI High-Definition Multimedia Interface, and HDMI logo is a trademark of HDMI Licensing LLC and is registered trademark in United States and/or other countries.

NewTek and NDI are registered trademarks of Vizrt Group.

macOS is a trademark of Apple Inc., registered in the U.S. and other countries.

Google Chrome is a trademark or registered trademark of Google LLC.

Other system names, product names appearing in this document are trademarks or registered trademarks of their respective manufacturers. Trademarked items are not indicated by ® or ™ symbols in this document.